

CENTER POINT HIGH SCHOOL
FORMERLY ERWIN HIGH SCHOOL
PROGRESS MEETING
APRIL 28, 2011



Wyatt

ATTENDEES / DISTRIBUTION LIST

28APR11

MEETING ATTENDEES:

Tony Page	Bhate	David Glasgow	Jeffco
Marilyn Acton	Gary C. Wyatt	George Henry	Jeffco
John Beane	Gary C. Wyatt	Jeff McCool	Jeffco
Josh Beane	Gary C. Wyatt	Mike Simmons	Jeffco
Matt Jackson	Gary C. Wyatt	Nels Strickland	Jeffco
Ginger Thompson	Gary C. Wyatt	Nathan Love	Love Landscapes
Gary Wyatt	Gary C. Wyatt	Bart Booher	MSE Building Company
Johnny Brown	A.S.I.	Blaine Carlisle	MSE Building Company
Van Moore	Automated Logic GA	Tom Moran	PCI
Marty DeVaughn	Brawco	Brian Conklin	Performance Contracting
Lee Culpepper	Charter Fire Systems	Joe Couturier	Quinco Electric
Sean Roberts	Charter Fire Systems	Danny Rollins	Quinco Electric
Bobby Attaway	Electronic Communication	J.L.	RPA, Inc.
Larry Hatchett	Flame-Tech	Duane Burt	Terrell
Brad Davis	H2K Construction	Paul Fisher	Victory
Jay Hambrick	H2K Construction	George Merchant	Victory
Jackie Keller	H2K Construction	David Shepherd	Victory
Carlos Lopez	J&C Roofing Co.	A.J. Wolnski	Wolnski Scheduling Services
Oscar Lopez	J&C Roofing Co.	Wade Giattina	Xcel Masonry
Jeremy Hays	J. Adkins	James McClanahan	Xcel Masonry

EMAIL DISTRIBUTION:

Michele Best, Van Phillips	Jefferson County BOE	Adam Vogel	Landscape Development
Dr. Rafael McDaniel	Jefferson County BOE	Chris Harkins	LBYP, Inc.
Dennis Isbell, Kevin Scott	Bhate	Linda Wright	Locker Pro, LLC
Gary Wyatt, Trish Belue	Gary C. Wyatt	Nathan Love	Love Landscapes
John Beane, Matt Jackson	Gary C. Wyatt	Dean Sternke	Mainstage Theatrical Supply
Corey Kennedy, G Thompson	Gary C. Wyatt	Stewart Lucas	Mancha Hardscapes
Kevin Sims	Abba Contract	Andrew Marlin	MBA Structural Engineers
Carl Bendolph	APCO	Matt Jones	MSE Building
Nico Suazo	ADP Lemco, Inc.	Scott Kragh	Nystram
Larry Tidwell	Alabama Specialties	Brian Conklin, Tom Moran	Performance Contracting Group
Suzette Britt	American Visual Display	Scott Phillips	Phillips Slipform
Van Moore	Automated Logic	Scott Masi, Danny Rollins	Quinco Electrical of GA
John English, Steve Burke	Brawco	Todd Whitson	Republic Storage Systems
Donnie Rigg, Jeremy Hyde	Building Specialties	Louise Howard	Restaurant Design Service
Jim Caradine	Building Specialties	Jim Parsons	Ron Bush, Inc.
Josh Woods, Sean Roberts	Charter Fire Systems	Elsie Cowart	RPA, Inc.
John Hallman, W. Chandler	Colonial Construction	Jeremy Garrett	Schindler Elevator
Chris Fain	Contractors Steel Supply	Nathan McCorkle	Shaw Contract Flooring
Richard Roden	Covington Flooring	Jon Pardee	Southeastern Interior Systems
Tim House	Eisys, Inc.	Brandon Streety	Southeastern Sealcoating
Neil King, Todd Hollingsworth	Evan Terry Associates	Gary Henley	Southern Lighting Group
Brandon Sisk, Jamie Lester	Ferguson Enterprises	Allen Ponder	Southern Woodsmith
Greg Metcalf	G&S Glass & Supply	David Dimmock	Tennessee Valley Metals
James Kimmel	Gerdau Ameristeel	Duane Burt	Terrell Enterprises
Jackie Keller	H2K Construction	Stuart Schatz	Texas Scenic
Jayma Bowling	Innerspace Architectural Interiors	Joe Miles	Tusco Fence
Carlos Lopez	J&C Roofing Co.	George Merchant	Victory Plumbing & Pipefitting
Rusty Gulsby, Jeremy Hays	J. Adkins Mechanical	Eric Leccese	Vining Corporation
J. Kimbrough, Michael Owen	J. Adkins Mechanical	Doug Rawson	Whitaker & Rawson
Philip Black	Jackson-Renfo & Assoc.	A.J. Wolnski	Wolnski Scheduling Services
Mike Wade	Joshco, Inc.	Wade Giattina	Xcel Masonry

HARD COPY DISTRIBUTION:

5 hard copies	Matt Jackson		
---------------	--------------	--	--

PROJECT TIMELINE

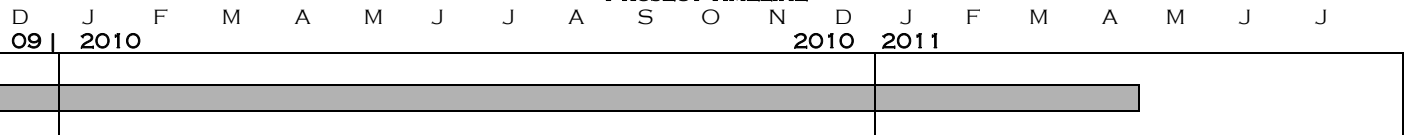

START

FINISH

NEXT MEETING: WEDNESDAY, MAY 12TH AT 9:00AM
 JOBSITE OFFICE TRAILER

PROGRESS MEETING SUMMARY

28APR11

JOB CONTACTS

Name	Title	Cell/Pager #	email
John Beane	Superintendent	205-966-2782	jbeane@gcwyatt.com
Ginger Thompson	Administrative Asst.	205-240-4498	gthompson@gcwyatt.com
Matt Jackson	Project Manager	205-229-8782	mjackson@gcwyatt.com
Josh Beane	Asst. Superintendent	205-365-5195	jbeane@gcwyatt.com
Marilyn Acton		205-985-3869	

JOBSITE ADDRESS & PHONE

The jobsite address is 2955 Jefferson St. Pkwy; Birmingham, AL 35215.

WORK HOURS

Work hours are 7:00AM to 3:30PM. Anyone needing to work outside these hours must see John Beane in advance. Anyone that wants to work on the weekend must notify Marilyn in writing by Noon the Wednesday before. Within a reasonable time Wyatt will respond with the answer about whether or not they will be able to work that weekend.

MEETING ATTENDANCE

The following subcontractors did not have anyone in attendance at today's progress meeting:

- G&S
- Charter
- Wolde
- J&C

Anyone with ongoing work or work scheduled to begin within the next 6 weeks is required to attend progress meetings. Anyone that is unable to attend a progress meeting should be sure to call Matt Jackson before the meeting begins to give him the opportunity to ask any questions that would have come up at the meeting.

Following is a list of the future meeting dates:

12MAY11 26MAY11 09JUN11 23JUN11 07JUL11

SAFETY

Wyatt holds regular safety meetings every Tuesday at 9:15AM. Attendance by all active subcontractors is required.

Following is a list of current safety concerns:

- A copy of all subcontractor's safety meeting minutes must be sent to Wyatt
- Reflective vests and hard hats are required at all times
- Everyone must have safety glasses with them at all times
- Backup alarms and seat belts are required on all equipment
- Keep rebar caps on rebar and anchor bolts
- Handrails must be replaced as quickly as possible anytime they are removed
- Temporary lighting to meet OSHA standards must be maintained
- A hand wash station is located outside the office trailer
- No one is allowed to ride in the back of any pickup trucks
- Everyone must be tied off on the roof even in areas with warning lines in place
- No glass bottles are allowed on site and no eating or drinking is allowed in the building
- Daily equipment inspection is required daily
- Overhead work – stay out from under welders – do not cross danger tape.
- Everyone must stay out from under scaffolds

PROGRESS MEETING SUMMARY (CONT.)

28APR11

CLEAN UP

All subcontractors are required to perform their own cleanup at the end of every day. John said that Wyatt has been doing most of the clean up work. Everyone else needs to do their share at the end of every day.

No eating or drinking is allowed in the building. No tobacco is allowed in any areas.

DAILY REPORTS

Daily reports are required to be turned in to John by 9:00AM the following day. Forms will be provided to subcontractors as needed. Daily reports are a condition for payment.

REQUESTS FOR INFORMATION

172 RFI's have been issued to date. All but 166, 168, 169, 170, 171 and 172 have been answered.

All RFI's are critical. An answer to RFI 166 is needed today.

LOST TIME

Below is a log of the number of days lost to date due to inclement weather.

Actual days		Claimable days	
January	4	January	0
February	8	February	0
March	8	March	3
April	3	April	1
May	10	May	5
June	8	June	4
July	6	July	0
August	6	August	4
September	2	September	0
October	5	October	1
November	9	November	5
December	6	December	0
January	8	January	0
Total	83		23

SUBMITTALS

Architect

There are currently no critical submittals past due.

Subcontractors

Following is a list of the most critical submittals needed from subcontractors:

- Pavement markings
- Fluid applied flooring - sample

PROGRESS MEETING SUMMARY (CONT.)

28APR11

CHANGE ORDER REQUESTS

54 COR's have been issued to date. A response has now been received on all outstanding COR's.

All Change Order requests must be accompanied by the proper supporting backup documentation.

PRICING

11 ASI's have been issued to date. Electrical COR revision pricing is needed.

DRAWING LOG

All drawings have been updated to include changes through ASI 11. As new drawings are issued a revised log will be distributed to each subcontractor's office and it is the responsibility of each subcontractor to make sure that copies of the revised drawings are distributed to their field personnel.

SCHEDULE

During the meeting A.J. reviewed and updated the near term schedule with all subcontractors present.

ACTION LIST

28APR11

	#	DESCRIPTION	RESP	TO BE DONE BY
<input type="checkbox"/>	72	List of all roof penetrations	Quinco	21FEB11 04APR11 21APR11
<input type="checkbox"/>	73	Spiral staircase delivery	Contractors Steel	ASAP 21MAR11 04APR11 27APR11 29APR11
<input checked="" type="checkbox"/>	75	Fab & deliver remaining catwalk	Contractors Steel	07MAR11 21MAR11 04APR11 27APR11
<input type="checkbox"/>	77	Notify Marilyn in writing by Noon Wednesday if you want to work on Saturday	All Subs	Ongoing
<input type="checkbox"/>	78	Precast delivery – remaining	Xcel	
<input type="checkbox"/>	79			
<input type="checkbox"/>	80			
<input type="checkbox"/>	81			
<input type="checkbox"/>	82			
<input type="checkbox"/>	83			
<input type="checkbox"/>	84			
<input type="checkbox"/>	85			
<input type="checkbox"/>	86			
<input type="checkbox"/>	87			
<input type="checkbox"/>	88			
<input type="checkbox"/>	89			
<input type="checkbox"/>	90			
<input type="checkbox"/>	92			
<input type="checkbox"/>	93			
<input type="checkbox"/>	94			
<input type="checkbox"/>	95			

Items denoted by an were reported to be complete at this meeting. They will be removed from the Action List at the next meeting













Gary C. Wyatt
GENERAL CONTRACTOR

GCW - Request for Information

Summary Log of all Outstanding RFIs

Erwin High School
2955 Jefferson State Parkway
Birmingham, AL 35215

Project # 09-06
Tel: 205-985-3860 Fax:

Gary C. Wyatt, Inc.

RFI #	Subject	Answer Company	Submitted	In Review	Date Req'd	Days Late	Amount	Delay
166	Feeder Schedule for Mechanical Equipment	Evan Terry Associates, P.C.	3/25/2011	34	4/1/2011	27		
168	Mechanical Exhaust Fan CEF3	Evan Terry Associates, P.C.	4/5/2011	23	4/12/2011	16		
169	Clarification of Unit Location	Evan Terry Associates, P.C.	4/11/2011	17	4/18/2011	10		
170	Condensation Drain Locations	Evan Terry Associates, P.C.	4/11/2011	17	4/18/2011	10		
171	Kiln Room Exhaust	Evan Terry Associates, P.C.	4/12/2011	16	4/19/2011	9		
172	Location for Auxiliary Rack/Electrical Requirements	Evan Terry Associates, P.C.	4/22/2011	6	4/29/2011	-1		

ACT ID	DESCRIPTION	RESP	ORIG DUR	REM DUR	PRED	SUCC	TF	2011																							
								APR			MAY			JUN			JUL			AUG			SEP			OCT					
								18	25	02	09	16	23	30	06	13	20	27	04	11	18	25	01	08	15	22	29	05	12	19	26
EXTERIOR																															
SITE																															
BW3010	SUBSTANTIAL COMPLETION	GCW	0	0	A1990, BE1990,	BW3020	0																								
BW3020	PROJECT CLOSEOUT	GCW	11	11	BW3010	BW3030	0																								
BW3030	PROJECT COMPLETE	GCW	0	0	BW3020		0																								
S1800	IRRIGATION	LOVE	93	17	S1120, S1510	S1810	55d																								
S1810	LANDSCAPING	LANDSCAPE	15	15	S1430, S1550,	S1920	55d																								
S1920	STRIPING & SIGNAGE	OUTHEAST	5	5	S1610, S1810,	BW3010	55d																								
AREA A																															
1ST FLOOR																															
A1290	TEMP PERMANENT POWER PANELS ENERGIZED	QUINCO	0	0	BW0610, P1340	A1300, BE0632,	7d																								
A1300	CONDITIONED AIR	JA	0	0	A1010, A1290	A1310, A1530,	7d																								
A1310	ACOUSTICAL CEILING TILE	ALABAMASF	10	10	A1280, A1300	A1670, A1690	20d																								
A1530	EPOXY FLOORING IN BATHROOMS	VINING	5	5	A1300, A1500	A1710	9d																								
A1540	MILLWORK	SW	5	5	A1305, A1600	A1670, A1690,	27d																								
A1630	COMPUTER FURNITURE	NNERSPACI	10	10	A1300, A1305,	A1780	19d																								
A1650	DOORS & HARDWARE	WILL	15	15	A1300, A1305,	A1780	16d																								
A1670	OWNER FURNISHED EQUIPMENT AT CONSUMER SCIENCES	OWNER	0	0	A1310, A1540	A1680	20d																								
A1680	INSTALL OWNER FURNISHED EQUIPMENT		5	5	A1600, A1670	A1960	20d																								
A1690	ELECTRICAL TRIM OUT	QUINCO	10	10	A1310, A1500,	A1700	22d																								
A1700	MARKER BOARDS / TACK BOARDS	AMERICAN	5	5	A1690	A1780	22d																								
A1710	PLUMBING FIXTURES AT BATHROOMS	VICTORY	8	8	A1530	A1760, A1970	9d																								
A1720	PLUMBING FIXTURES AT MILLWORK	VICTORY	5	5	A1305, A1540	A1970	35d																								
A1760	TOILET ACCESSORIES	TA	5	5	A1710, A1750	A1780	9d																								
A1770	LOCKERS	LOCKERS	5	5	A1305, A1600	A1780, BE1790,	2d																								
A1780	SIGNAGE	GCW	3	3	A1630, A1650,	A1960	2d																								



SCHEDULE OF REMAINING WORK

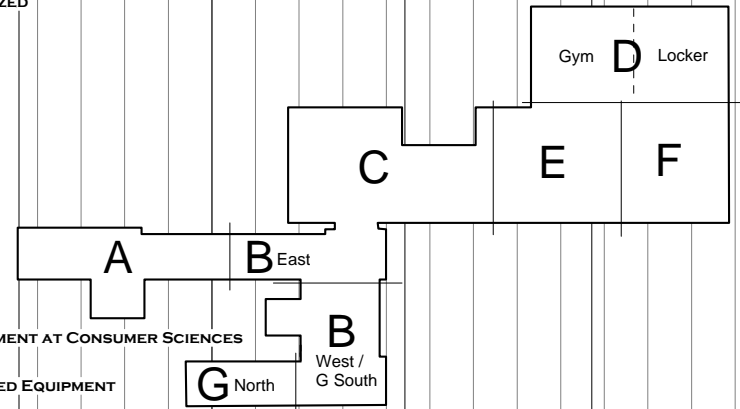

- Early bar
- Target bar
- Progress bar
- Critical bar
- Start milestone point
- Finish milestone point

NEWERWIN (SURETRAK)
 REPORT: EHS7
 LAYOUT: NEAR TERM SCHEDULE
 FILTER: REMAINING WORK

ERWIN HIGH SCHOOL
GARY C. WYATT, INC.

RUN DATE: 02MAY11
 DATA DATE: 28APR11
 JOB# 1002
 PAGE 1A OF 14A



